

Floor/Ceiling, Precast Concrete

REFERENCE: FIRM-FILL® BRAND GYPSUM CONCRETES

PRODUCT ASSEMBLY

1. Hacker TopCoat®SP

An acrylic-based, film forming surface preparation agent.

2. (a) FIRM-FILL® 3310

Has compressive strengths from 2000-3350 psi (ASTM C472).

(b) FIRM-FILL® High Strength

Has compressive strengths from 2500-3800 psi (ASTM C472).

(c) FIRM-FILL® 4010

Has compressive strengths up to 5000 psi (ASTM C472).

3. Hacker Floor Primer

A rewettable latex primer that is diluted: 1 part Hacker Floor Primer to 4 parts water.

Note

Some installation methods and components are not referenced. Please consult all approved resources to ensure a complete assembly.

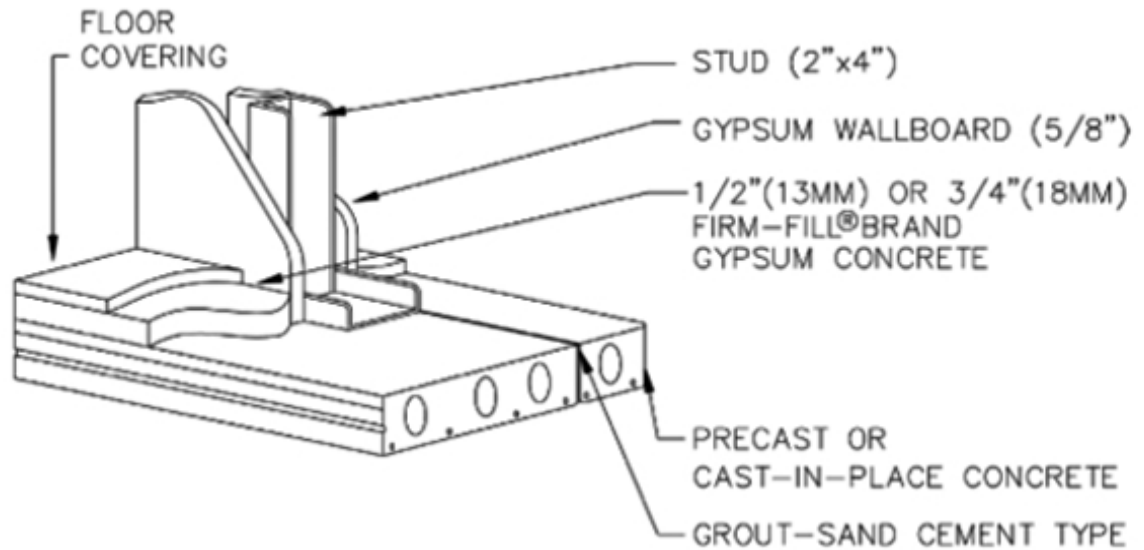

When installed at 1/2" (13mm) or 3/4" (19)mm over precast concrete, FIRM-FILL® Brand Gypsum Concrete achieves excellent fire and sound ratings while providing a superior crack-resistant surface for the installation of finished floor coverings.

Precast Concrete

2 hr	J917, J927
1.5-4 hr	J991, J994
2-3 hr	J919, J920, J931, J957
2-4 hr	J924

HACKER INDUSTRIES, INC.
1600 Newport Center Drive
Newport Beach, CA 92660

PHONE
(949) 729-3101

WEB
www.hackerindustries.com
info@hackerindustries.com