



Floor/Ceiling, Parallel Chord Truss

REFERENCE: 0.75" FIRM-FILL® BRAND GYPSUM CONCRETE PLUS FIRM-FILL® SCM-125

PRODUCT ASSEMBLY

1. Hacker TopCoat®SP

An acrylic-based, film forming surface preparation agent.

2. (a) FIRM-FILL® Gypsum Concrete

Has compressive strengths from 1200-2000 psi (ASTM C472).

(b) FIRM-FILL®2010+

Has compressive strengths from 2000-3200 psi (ASTM C472).

(c) FIRM-FILL®3310+

Has compressive strengths from 3000-4250 psi (ASTM C472).

3. Hacker Floor Primer

A rewettable latex primer that is diluted 4:1

Note

Some installation methods and components are not referenced. Please consult all approved resources to ensure a complete assembly.

When FIRM-FILL® Brand Gypsum Concretes are installed over open web, deflection may not exceed L/360. There is a risk of higher strength materials (over 3,000 psi) cracking due to differential movement. The higher the floor, the more differential movement is to be expected.

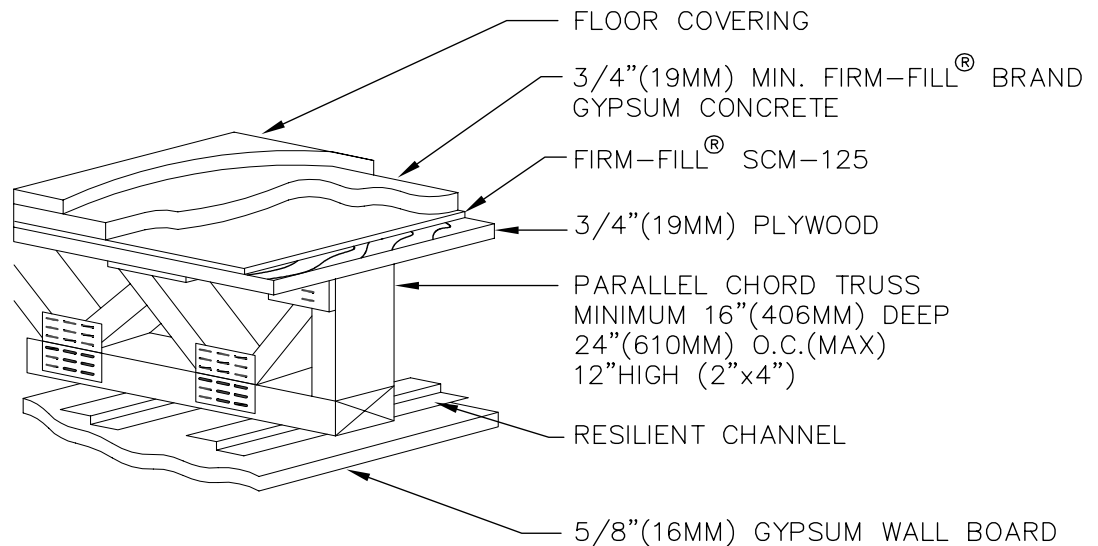

When installed over open web, 0.75" (19mm) FIRM-FILL® Brand Gypsum Concrete and 1/8" (3mm) FIRM-FILL® SCM-125 achieve excellent fire and sound ratings while providing a superior crack-resistant surface for the installation of finished floor coverings.

Parallel Chord Truss

1 hr	w/ Insulation and Resilient Channel	L528, L546, L558, L563, L574, L585, L592, M503, M508
1 hr	w/ Resilient Channel	L528, L534
1 hr	w/ Resilient Channel & U.S. Greenfiber	L521
1 hr	w/ Resilient Channel and Insulation (or Loose Fill Material)	L550
1 hr	w/ Kinetics Ceiling Hangers	L583
1 hr	Direct Attached Drywall	L529, L542
2 hr	w/ Three (3), or more, Layers of Drywall	L556, M503

HACKER INDUSTRIES, INC.
1600 Newport Center Drive
Newport Beach, CA 92660

PHONE
(949) 729-3101

WEB
www.hackerindustries.com
info@hackerindustries.com