

August 2013

## The Residences at 19th & Logan Denver, Colorado

The Residences at 19th and Logan are an exciting new project in Downtown Denver. The area is known for its historic homes, businesses and walkable neighborhoods. The apartment community will include four separate buildings as well as retail shops, commercial space and restaurants. Each building will be named after a Denver city park. The buildings have been architecturally designed to match the character of several Denver landmark buildings. Construction began in early 2012 and is planned to be completed in the fall of 2013.

For more than 10 years, **Gypsum Floors of Denver, LLC** has prided themselves on providing superior products and outstanding service to the Colorado market. This has resulted in longtime customers who value their quality, honesty and loyalty. Gypsum Floors of Denver specializes in gypsum concrete underlayment, acoustical sound control mats and hard rock concrete for multi-family, custom homes, commercial buildings, and renovation projects.



Gypsum Floors of Denver is working closely with **Saunders Construction, Inc.** in the ongoing construction of the **The Residences at 19th & Logan**. Saunders Construction has been ranked as one of the largest general contractors in Colorado with over \$4 billion in successful projects.

Gypsum Floors of Denver is using **FIRM-FILL® 3310 Classic** on this project, which is an innovative formulation that results in a rock-solid floor, up to 3300 psi combined with a sound abatement mat. It maximizes sound control and creates a flat, non-structural, smooth surface for finished floor coverings. The surface can be walked on within 90 minutes. Finished floor coverings can be installed in 7-14 days, depending on thickness and drying conditions.

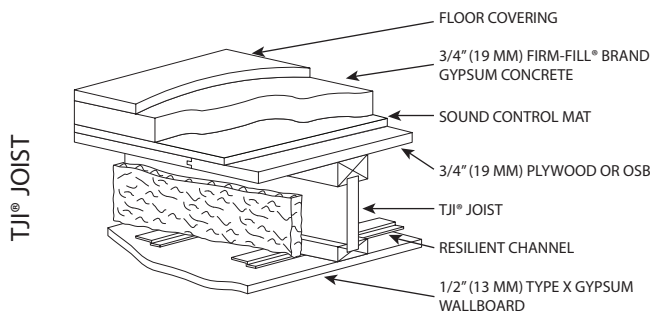

Job Highlights	
General Contractor:	Saunders Construction Inc.
Applicator:	Gypsum Floors of Denver
Project:	The Residences at 19th & Logan
Assembly:	3/4" TJI Wood Joist
Application:	FIRM-FILL® 3310 Classic
Square Feet Installed:	288,000 of 3310 Classic 160,000 of SCM-250