



Floors, Interior; Vinyl over Radiant

REFERENCE: RADIANT PANEL ASSOCIATION-WWW.RADIANTPROFESSIONALSALLIANCE.ORG or (877)427-6601

PRODUCT ASSEMBLY

1. Hacker TopCoat®SP

An acrylic-based, film forming surface preparation agent.

2. GYP-SPAN® Radiant

Specially designed for Radiant Systems ASTM C472. Compressive strengths from 2000-3200 psi.

3. Hacker Floor Primer

A rewettable latex primer that is diluted: 1 part Hacker Floor Primer to 4 parts water.

Note

Some installation methods and components are not referenced. Please consult all approved resources to ensure a complete assembly.

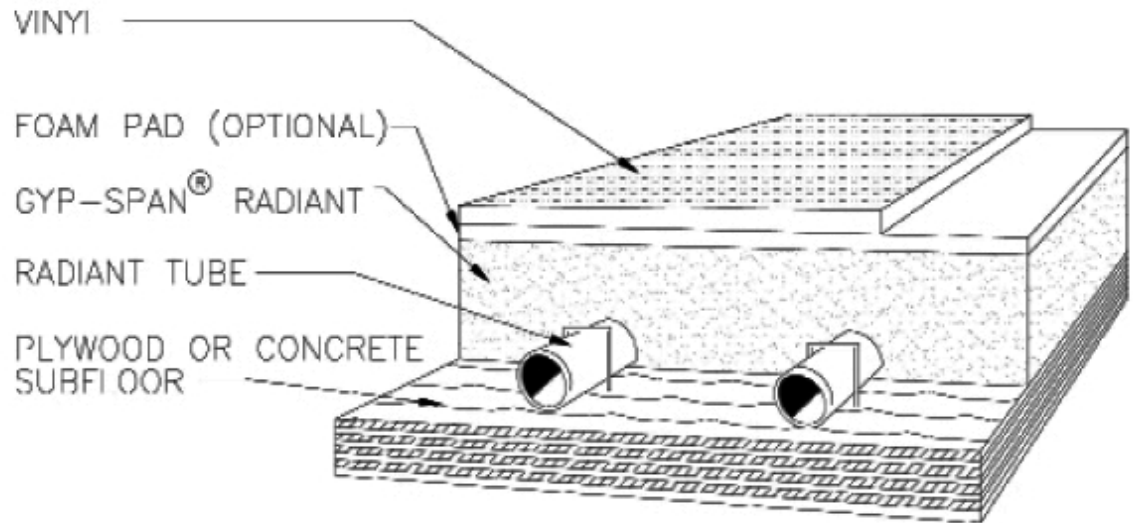

When installing sheet vinyl and vinyl composition tiles over GYP-SPAN® Radiant Gypsum Concretes:

Before, during and after installation of GYP-SPAN® Radiant, building interior must be ventilated and heated to a minimum 50°F (10°C) to assure completion of the drying process. The General Contractor shall provide continuous ventilation and adequate heat to rapidly remove moisture from the area until the GYP-SPAN® Radiant is dry. Do not install finished floor coverings until the GYP-SPAN® Radiant has been tested for dryness. Consult flooring contractor for recommended procedures to test for dryness. Reference Hacker Industries, Inc.'s Drying Condition Flyer.

Once dry, temperature of the radiant heat system must be lowered before applying any floor covering, adhesive and/or floor covering.

Allow adhesive to cure at least seven days before turning on hydronic or electric cable heat systems to allow material to hydrate adequately. Consult the Radiant Panel Association Guidelines.

Sheet Vinyl and Sheet Vinyl Composition Tiles:

According to the resilient industry recommendations, the floor surface temperature should never exceed 85°F (29°C). During adhesive and tile installation, lower the floor temperature. Consult Radiant Panel Association Guidelines and/or manufacturer of flooring material to be used prior to installation for specific requirements.

Radiant Panel Association-www.radiantprofessionalsalliance.org or (877) 427-6601

HACKER INDUSTRIES, INC.
1600 Newport Center Drive
Newport Beach, CA 92660

PHONE
(949) 729-3101

WEB
www.hackerindustries.com
info@hackerindustries.com