



# Floors, Interior; Ceramic, Quarry or Marble Tile

REFERENCE:

## PRODUCT ASSEMBLY

### 1. Hacker TopCoat®SP

An acrylic-based, film forming surface preparation agent.

### 2. (a) FIRM-FILL® 2010

Has compressive strengths from 1950-2750 psi (ASTM C472).

### (b) FIRM-FILL® 3310

Has compressive strengths from 2000-3350 psi (ASTM C472).

### 3. Hacker Floor Primer

A rewettable latex primer that is diluted: 1 part Hacker Floor Primer to 4 parts water.

#### Note

Some installation methods and components are not referenced. Please consult all approved resources to ensure a complete assembly.

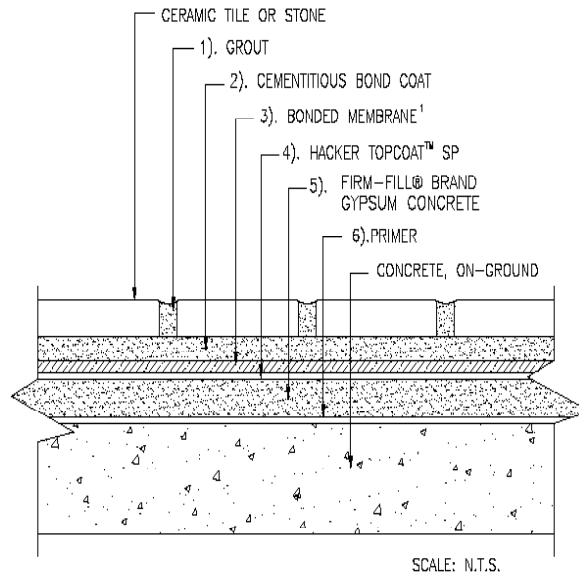

NOTE: ¹BONDED MEMBRANE MAY NOT BE COMPATIBLE WITH HACKER TOPCOAT™ SP. PLEASE CONTACT THE BONDED MEMBRANE MANUFACTURER FOR THEIR RECOMMENDATION.

## When installing ceramic, quarry, and/or marble tile over FIRM-FILL® Brand Gypsum Concrete: Hacker Industries, Inc. encourages deference to the recommendations of the Tile Council of North America.

### Tile Council of North America:

As noted in their handbook, TCNA strongly recommends an anti-fracture membrane be installed between the underlayment and ceramic tile, as recommended by the membrane and setting material manufacturer.

most MAPEI polymer-modified or epoxy mortars.

The Hacker Floor Underlayment must be dry prior to membrane installation, unless otherwise stated by the membrane manufacturer.

### Benefits of Mapelastic™CI Professional Crack Isolation Membrane:

Mapelastic CI is a pre-mixed, liquid-rubber, quick drying crack-isolation membrane for installation under ceramic tile or stone in residential and commercial interior and exterior environments. Mapelastic CI meets ANSI A118.12 requirements, provides up to 1/8" (3mm) of in-plane crack isolation, and dries after about 30-50 minutes. It is then ready to receive

For questions or to purchase Mapelastic, contact Mapei at (800) 426-2734 or visit [www.mapei.com](http://www.mapei.com).

### Movement Joints:

Adhere to expansion joint requirements found in the Handbook for Ceramic Tile Installation under EJ171 specification. Contact the Tile Council of America (TCA) at (800) 646-8453 or [www.tileusa.com](http://www.tileusa.com) for a copy of the handbook.

**HACKER INDUSTRIES, INC.**  
1600 Newport Center Drive  
Newport Beach, CA 92660

**PHONE**  
(949) 729-3101

**WEB**  
[www.hackerindustries.com](http://www.hackerindustries.com)  
[info@hackerindustries.com](mailto:info@hackerindustries.com)